

ISLAND III *blu*



The Charnwood Island III is the largest stove in the Island collection. Its majestic proportions make it ideal for larger rooms and open plan areas. Exuding a rated 12kW of heat, this is a stove that can take an incredible log length of over half a metre. The Island III offers a spectacular view of the fire. A true wide-screen experience. Optional convection panels are also available. This model is SIA Ecodesign ready (blu).

RATED OUTPUT

11kW to room (range **8-16kW**)

NET EFFICIENCY

79%

FLUE OUTLET

Top or Rear **178mm (7")** dia

MAX LOG LENGTH



611mm (24")

MIN DISTANCE TO COMBUSTIBLES

Side: **600mm** Rear: **600mm**

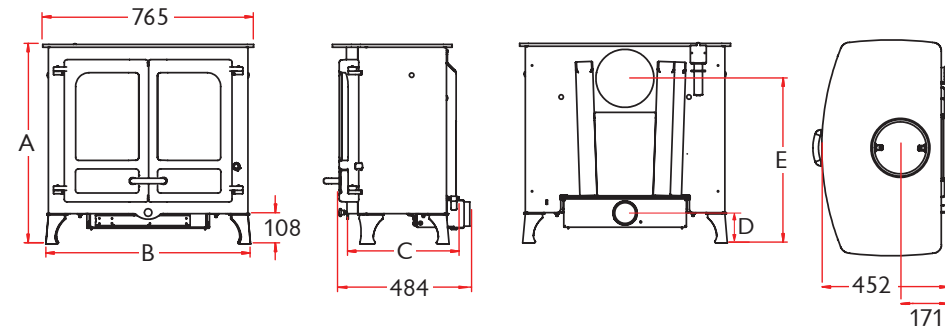
With panels / heatshield - Side: **335mm** Rear: **335mm**

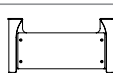

		A	B	C	D	E	WEIGHT
LOW LEGS		713	732	400	107	588	180KG
HIGH LEGS		795	750	400	189	670	184KG
STORE STAND		945	714	309	339	820	197KG